

Attachments

MDB TF Series.



The MDB TF Series is designed as a forestry flail, to cut brush, reeds, bamboo and hardwood trees for the Green Climber line.

POWERFUL.

The **TF Series** combines strong hydraulic pumps and rotating teeth which provides cutting power for grass, weeds, reeds, bamboo and small hardwood trees of up to 20 cm / 8 in.



DURABILITY.

The hydraulic adjustable cover plate provides maximum impact protection to the internally integrated lifting cylinder.

CONTROL.

The front breaker bar provides leverage in helping push materials over and the front teeth provide control of cut materials from falling to the sides.



FLESSIBILE.

Disponibile in 3 diverse larghezze di taglio: 125 cm, 130 cm, and 150 cm: di taglio TE 125, TE 130 and TE 150.

MAXIMUM RELIABILITY.

The optimized power transmission system features 4 belts to offer maximum reliability.

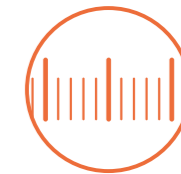

PRECISION MULCHING.

Strong and durable teeth reinforced with high resistance steel, combined with a fixed set of counter-rotating teeth result in a fine mulch.

TECHNICAL SPECIFICATIONS

Dry Weight	390 kg / 550 kg / 605 kg
Hydraulic Motor Upgrade	32 cc
Cutting Options	30 / 33 / 36 Teeth
Safety Front Rubber Pads	Yes
Safety Rear Chains	Yes
Ground Hugging Skid	Yes
Floating Plate Compatibility	Yes

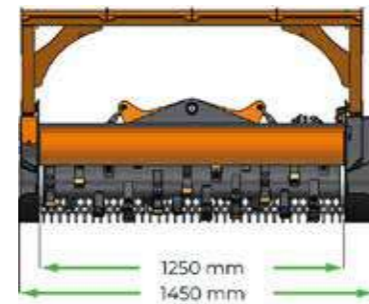

TF 125

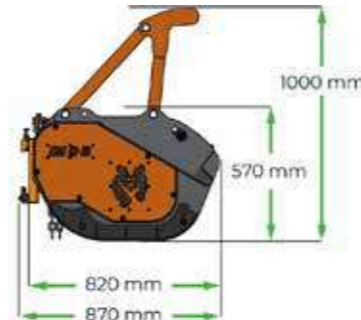
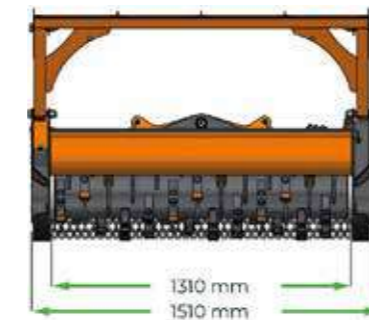

TF 130

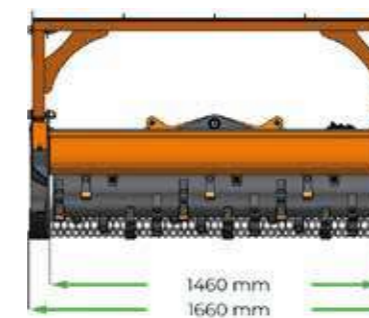

TF 150

