

MDB



SINCE 1977

GREEN CLIMBER

F 23



**A COMPACT BI-DIRECTIONAL
MACHINE WITH NO FEAR OF
EVEN THE TOUGHEST TASKS.**

**AN AGILE GRASS AND WEED CUTTER THAT CAN
HANDLE SLOPES OF UP TO 60° AND TIGHT SPACES.**



DURABILITY

The F 23 is a specialist machine with an undercarriage built from high strength materials with a corrosion resistant coating.



VERSATILE

The height of the cutting blade can electronically be adjusted to continue working on different types of terrain.



GREATER STABILITY

The low center of gravity and high profile tracks achieve an unrivalled stability on uneven and steep terrain up to 60° grade.



ALWAYS READY FOR ACTION

The Smart Battery System (SBS) is an integrated sealed compartment that houses a battery charger for the remote control. The spare battery recharges automatically while the machine is working.



TOW CAPABILITY

A sturdy hitch for connecting a trailer or cart.



SAFETY

The remote control integrates all movements. Driving is extremely easy and precise with a single joystick to operate and steer the tracks.



Green Climber – F 23

TECHNICAL SPECIFICATIONS

Dry Weight	570 kg
Work Gradient	60°
Engine	KAWASAKI FX730V EFI
N. of cylinders	2
Engine Power	22.2 hp / 16.6 kw
Engine Torque	54.3 Nm @ 2000 rpm
Emissions	Stage V - EPA Tier 4 Final
Fuel Tank Capacity	20 L Petrol
Cooling System	Air Cooled
Drive Train	Hydrostatic Transmission
Transmission	Belt Drive with Electromagnetic Clutch
Speed	10 km/h
Cutting Width	80cm
Cutting Height	5 - 11 cm Electronically Adjustable
Number of Blades	2 Delta Blades

© MDB Srl 2022 - Image, technical and construction specifications subject to change with no obligation of prior notification. All rights reserved.

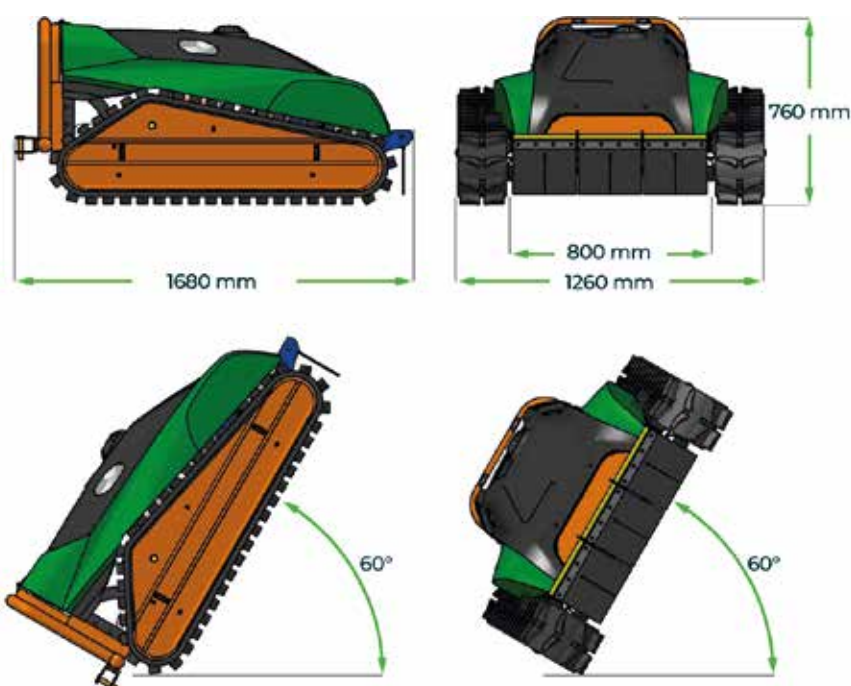

MDB srl

www.mdb srl.com

Via Cupone 13
66022 Fossacesia (CH)
Italia

